

Torque Speed/Current (TYP.) Characteristics FH6S(PF)20R-D3+FHD620RD3

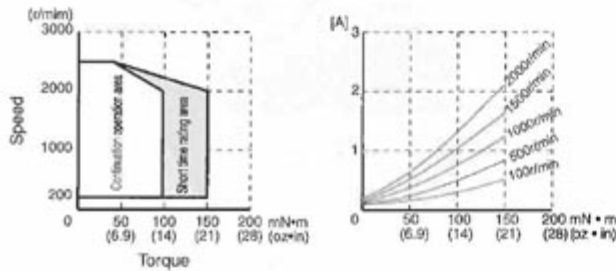

FH6S(PE)40R-D3+FHD640RD3

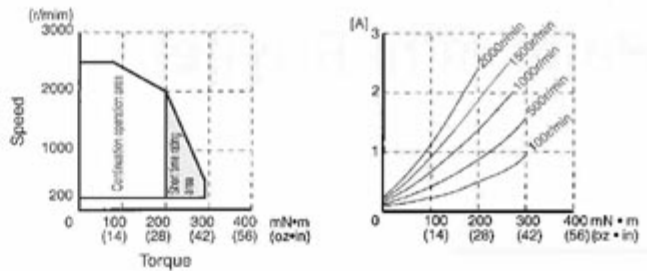

Input & output terminals and wiring diagram

Item	Pin No.	Read Wire Color	Symbol	Input or Output	Function	Standard · Condition	
Power supply	1	Red	VM	Input	Power supply positive for driver	DC24V±10%	
	2	Black	P.GND	—	Power supply GND for driver		
I/O	1	Brown	ALARM OUT	Output	H: Normal operation L: Alarm output	H: Open collector L: 0.6V MAX. Output DC30V MAX. & 2mA MAX	
	2	Red	SPEED OUT	Output	42 Pulse /Revolution ※1		
	3	Orange	F/R OUT	Output	H: CCW L: CW (Viewed from motor output shaft side)		
	4	Yellow	F/R IN	Input	H: CCW L: CW order (Viewed from motor output shaft side)		
	5	Green	BRAKE ※	Input	H: BRAKE Deactivated L: BRAKE activated it functions in RUN signal "L"		
	6	Blue	RUN	Input	H: Stop L: Start It functions in RUN signal "L"		H: Open collector L: 0~1.5V
	7	Purple	HT	Input	H: Holding torque OFF L: Holding torque ON It functions in RUN signal "L"		
	8	Gray	INT	Input	H: The motor is controlled by the speed voltage from the inside command. L: The motor is controlled by the speed voltage from the External command.		
	9	White	GND	—	GND for I/O signals		
	10	Black	VR	Output	Power supply positive for external speed setting		
11	Brown	VS	Input	Speed setting signal positive	0~10V		
12	Red	GND	—	Speed setting signal GND			

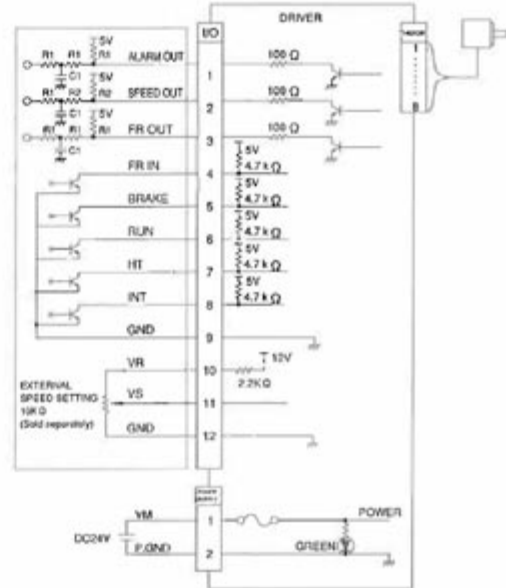

Part name	Recommended value
R1	4.7KΩ
R2	1KΩ
C1	0.01μF

- ※1 The speed output signal is as follows.
- ※2 · Reverse rotation brake and short circuit brake
- "BRAKE" has priority over "RUN".
- During rotation direction switching operation, "BRAKE" terminal voltage may reduce due to internal processing.

※1 "SPEED OUT" signal is shown below

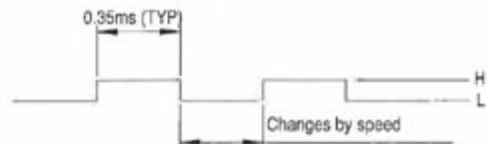

Protection

Protection function	Protection		Alarm Release
	Description	Operation	
Overload Protection function	Activated when the load exceeds the rated torque for more than 5 seconds. Disconnection protection in hall IC	The driver will cause the motor to stop and "ALARM" will output "L".	Alarm is released when Run-signal was inputted 2 times or shut-down the supply voltage more than 1 minute period.
Disconnection-protection in hall IC	The protection operates when the abnormal feed-back signal appeared from the motor.	The LED will blink for the corresponding number of times shown right chart.	(When release the protection, two times Run-signal input shall be done within one sec.)
High & Low voltage-protection	Activated when the power supply voltage exceeds about 27.6 VDC or drops below about 18 VDC for more than 1 second.		
Acceleration protection	Activated when the actual motor speed exceeds 15% higher than the specified speed for more than 1 second.		
Overspeed protection	Activated when the temperature of PCB surface inside of the driver exceeds about 85 °C.		

Protection name	LED Blinking
Overload Protection	1 time
Disconnection protection of Hall IC signal	2 times
High & Low voltage-protection	3 times
Acceleration protection	4 times
Overspeed protection	5 times

Note. The above LED blinking are repeated by the each two seconds period.

The confirmation of load is more than or less than rated load, it is not checked by using over-load protection operation and less than rated load operation shall be prepared.

Control sequence

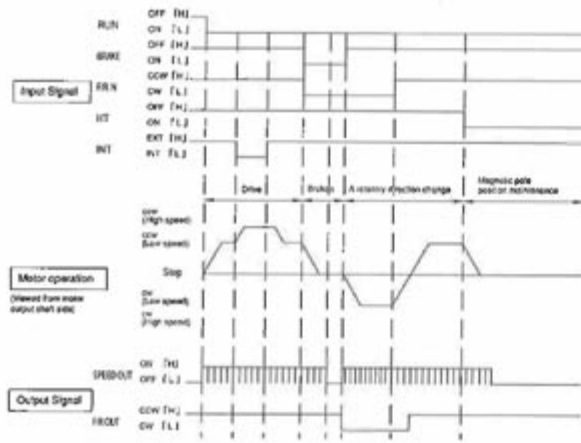

The INT signal is the signal that switches internal speed specified voltage and external speed specified voltage. In this control sequence, the voltages are set up as internal speed voltage for low speed and external speed voltage for high speed operation.

[Notes for BRAKE Operation & Rotation change]

(1) When actual motor speed is higher than the setting (by signal input value of "VS"), any switching of the "F/R IN" and "BRAKE" ("H-L") must not be made.

(2) During the brake is operating, set the "RUN" signal at "L" all the time.

WARNING:

in case of different way of use from (1) and (2), (2) may be the cause of the incorrect operation and (1) may be the cause of the fire or the breakdown.

Electrical shock: By the load condition, the terminal voltage (VM) is raised up to 30 VDC, during switching BRAKE and/or Rotation direction.

(Braking Operation: At higher speed, the reverse rotation brake is applied first, then the short circuit brake is applied. But at slower speed, only the short circuit brake will be applied.)

For repeated the "F/R IN" and/or the "BRAKE" inputs, maintain at least a 3 second interval.

While the motor is in stop, the "F/R OUT" is held at the same signal as previously output.

This means; if the motor stopped once, but the rotation reversed by cogging torque or by the Load, then the "F/R OUT" is held at reversed signal.

Speed setting

Fig.1 Speed setting by external speed setter

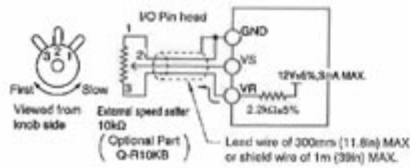

Fig.2 Speed setting by external voltage supply

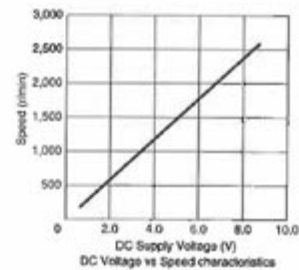
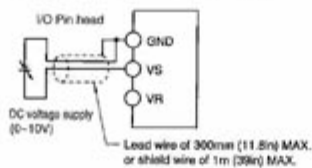
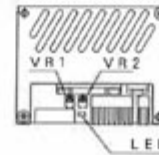

Fig.3 Driver external from and internal organs LED and a trimmer



VR1 : Acceleration time adjustment
VR2 : Inside speed order
LED : At the time of normal driving : Lighting Electricity : Lights out Protection function movement in a state



VR1 : Acceleration time adjustment VR2 : Inside speed order

Item	Setting Method
Speed setting by external speed setter (Optional Part)	Connect as shown in Fig.1 and set by external speed setter. Use variable resistor 10[KΩ] as an external speed setter.
Speed of internal speed setting device	The speed setting is done by VR2 of Fig.3 But I/O 8pins INT signal is defined as "H".
Speed setting by external voltage supply	Connect as shown in Fig.2 and set speed by external voltage supply.

By these function, it is possible to set a speed at outside of Speed control range. But it must be out of our product warranty.

Driver outline Unit: mm (inch)

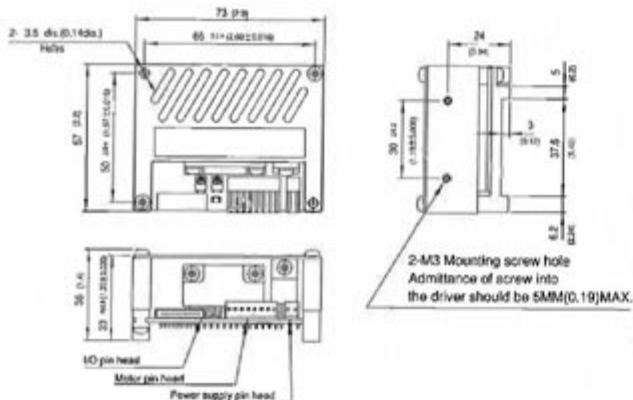

Accessory Unit: mm (inch)

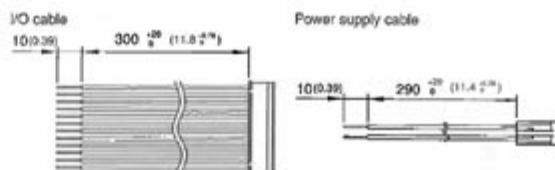

Connector model code

Item	Pin head model code on drive	Connector model code on cable		Maker
		Housing	Contact (chained)	
I/O connection	171826-08	171822-8	170262-1	AMP
Power supply connection	171826-02	171822-2	170262-1	
Motor connection	512B-ZR-5M4A	ZHR-12	SZH-002T-P0.5	JST

■Motor outlines (Plain shaft type) Unit: mm (inch)

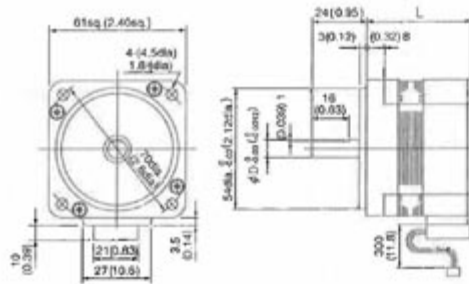

	Model	L	Weight	
			Kg	(lb)
①	FH6S20R-D3	46 (18.1)	0.5	1.1
②	FH6S40R-D3	60 (2.36)	0.7	1.5

	①② PIN #	Lead wire color	Item	Remark
Motor connector	1	Purple	HU	Open collector
	2	Blue	HV	Open collector
	3	Green	HW	Open collector
	4	White	12V	
	5	Gray	GND	
	6	Orange	Coil W	
	7	Red	Coil V	
	8	Brown	Coil U	

■Motor (Pinion shaft type) + Gear head outlines

FH6PF20R-D3+6H□EBN

Unit: mm (inch)

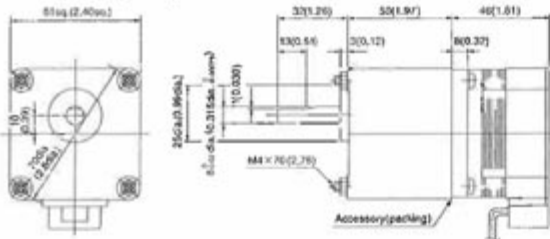

Gearhead weight 0.5Kg (1.1lb)
Bolts (accessory) M4 x 7.0 (2.76)

FH6PE40R-D3+8F□EBN

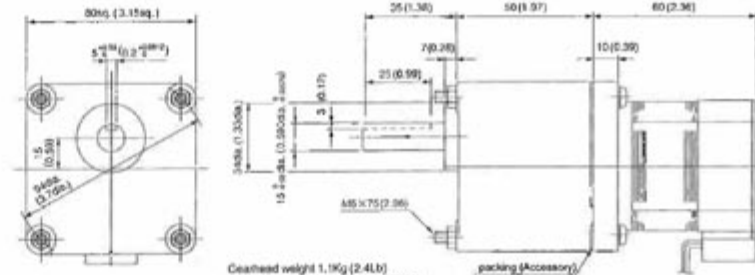

Gearhead weight 1.9Kg (2.4lb)
Bolts (accessory) M5 x 7.5 (2.96)
Key (accessory)

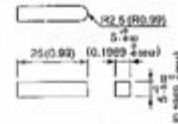

■Motor/Driver/Cable/Rotor cover model code table Unit: mm (inch)

		Motor model code	Driver model code	Power supply cable model code	Motor cable model code	I/O Cable model code
FHD series	Palm mini R type	FH6S20R-D3	FHD620RD3	FHD-CNTL03 300 (11.8)	FHD-CNEL02-03 200 (7.9)	FHD-CNRL03 300 (11.8)
				FHD-CNTL05 500 (19.7)	FHD-CNEL07-03 700 (27.6)	FHD-CNRL05 500 (19.7)
				FHD-CNTL10 1000 (39.4)		FHD-CNRL10 1000 (39.4)
		FH6PF20R-D3	FHD620RD3	FHD-CNTL03 300 (11.8)	FHD-CNEL02-03 200 (7.9)	FHD-CNRL03 300 (11.8)
				FHD-CNTL05 500 (19.7)	FHD-CNEL07-03 700 (27.6)	FHD-CNRL05 500 (19.7)
				FHD-CNTL10 1000 (39.4)		FHD-CNRL10 1000 (39.4)
		FH6S40R-D3	FHD640RD3	FHD-CNTL03 300 (11.8)	FHD-CNEL02-03 200 (7.9)	FHD-CNRL03 300 (11.8)
				FHD-CNTL05 500 (19.7)	FHD-CNEL07-03 700 (27.6)	FHD-CNRL05 500 (19.7)
				FHD-CNTL10 1000 (39.4)		FHD-CNRL10 1000 (39.4)
		FH6PE40R-D3	FHD640RD3	FHD-CNTL03 300 (11.8)	FHD-CNEL02-03 200 (7.9)	FHD-CNRL03 300 (11.8)
				FHD-CNTL05 500 (19.7)	FHD-CNEL07-03 700 (27.6)	FHD-CNRL05 500 (19.7)
				FHD-CNTL10 1000 (39.4)		FHD-CNRL10 1000 (39.4)

※The power supply cable types for FHD series are the same as those for FED series.

The I/O cable types for FHD series are the same as those for FYD series.